

# Viking Turbo Beaver

**VIKING** 



***VERSATILITY THAT WORKS***

Versatility and reliability on water, snow, tundra or tarmac.

# Product Information



## TURBO

# Beaver

The legendary Turbo Beaver has earned the reputation as one of the most practical, versatile, rugged and reliable aircraft in the air today. Viking has seen over ninety percent of the original fleet through our hangar doors, and has extensive knowledge on type. This experience has lead Viking to improving and modernizing the DHC-2 Beaver to make it a logical choice for both private and commercial operations.

Converted from Piston utilizing original factory specifications, the Viking Turbo Beaver is essentially an all-new aircraft featuring a longer cabin and larger payload, with more power and better all around performance from the PT6A-27 or optional PT6A-34 engine.

Available on optional land gear, straight or amphibious floats, skis or wheel skis, the Turbo Beaver is a versatile aircraft that can be configured for and called upon in any operating environment.

Improving upon legendary design with modern options, the Viking DHC-2T Turbo Beaver offers improved performance and "Versatility That Works".

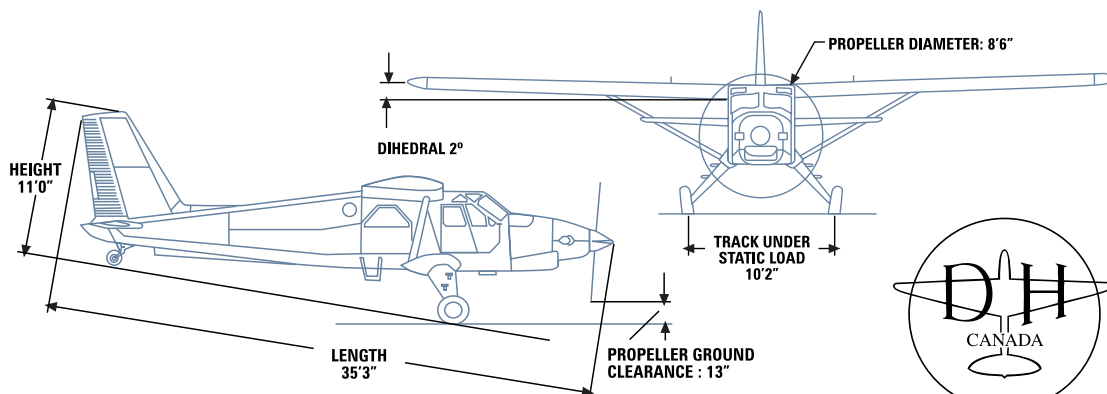

NOTE: Dimensions are approximate only and may vary depending on aircraft configuration and loading conditions.

**WING SPAN:** 48' (Tip to Tip)  
**LENGTH:** 35' (Propeller to Tail)  
**HEIGHT:** 17' (Tail to Ground)

### FEATURES:

1. Larger tail for increased rudder authority
2. Elevator finlets for more effective directional control
3. 9 cu.ft. of float storage
4. Fuel caps updated to jet fuel configuration. Convenient belly fueling.
5. Standard 3 blade Hartzell reversible prop or optional paddle prop for improved take-off thrust
6. de Havilland designed wing fences for better STOL performance
7. Greater visibility for pilot and co-pilot
8. Dual landing lights
9. Cabin extension adds 29 cu.ft. Alaska Door optional for large payload items.
10. Flow generators for increased aileron effectiveness
11. Custom designed exhaust for Turbo Beaver

### PERFORMANCE: with Wipaire 6100 Amphib Floats

Engine:	PT6A-27/-28,-34
Take Off Power:	680 HP
Gross Weight:	6000 lbs
Seats:	Standard: 8+pilot Optional: 10+pilot
Fuel Capacity:	186 gallons (U.S.)
Range: (statute miles)	604 SM
Max. Endurance:	5.98 hours
Useful Load:	Landplane: 2973 lbs Amphibious: 2100 lbs
VNE:	Landplane: 176 mph Amphibious: 160 mph
VNO:	141 mph
Take Off Distance:	Land: 1026 ft Water: 1830 ft
Over 50' Obstacle:	2085 ft (water)
Rate of Climb:	1425 fpm (feet per minute)



## VERSATILITY THAT WORKS

Toll Free: 800-663-8444 | International: 800-6727-6727 | info@vikingair.com | www.vikingair.com  
 Corporate Address: Victoria International Airport 1959 de Havilland Way Sidney, British Columbia V8L 5V5 Canada